

## TECHNICAL SPECIFICATIONS

# FISCHER MINIMAX™ SERIES

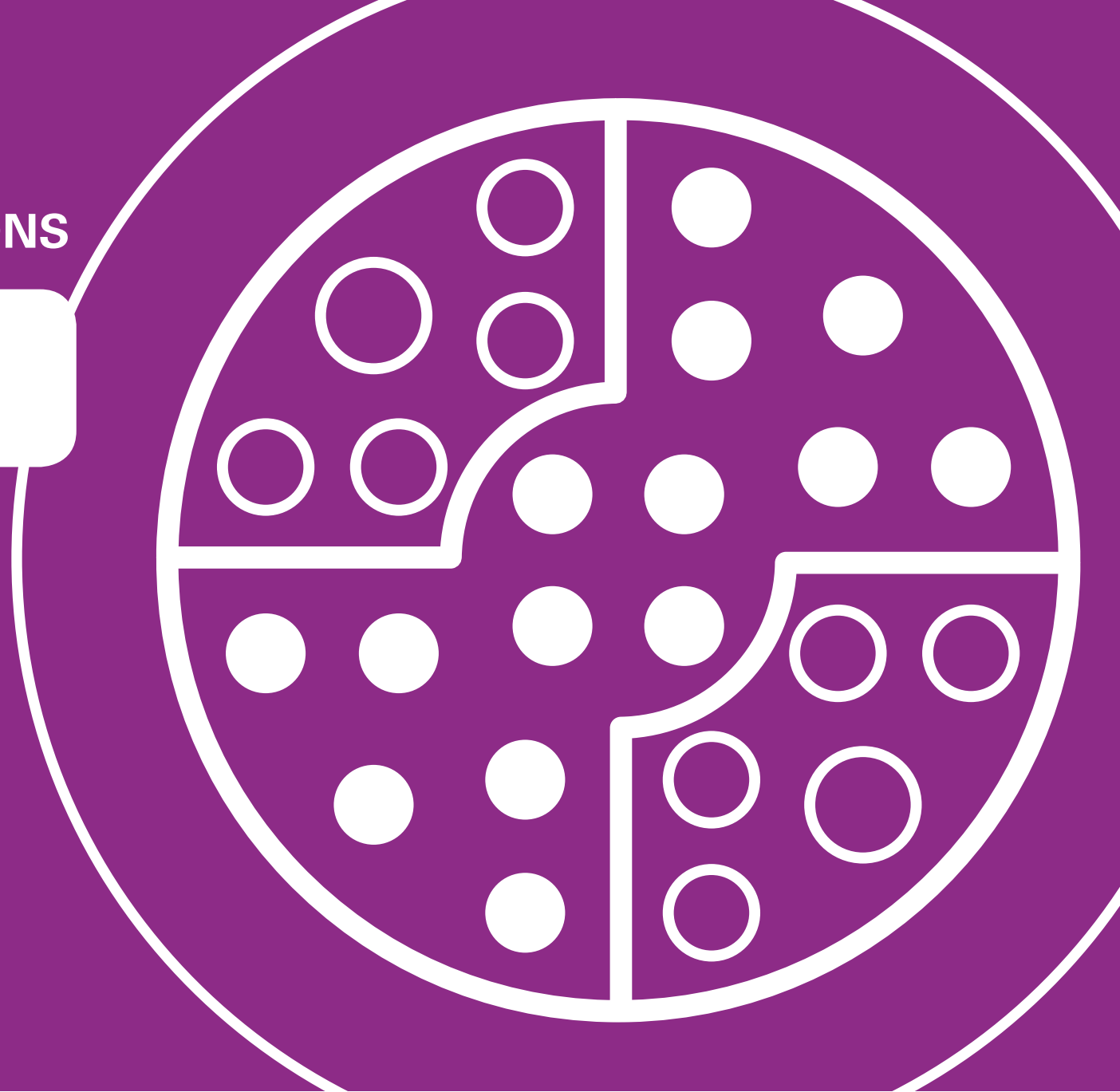



## KEY FEATURES



The Fischer MiniMax™ Series increases the performance of your miniature rugged devices, handling more mixed signal and power connections in a unique combination of up to 24 contacts. This high performance rugged connector will save space and weight and lower the total cost of ownership by putting more functionality into smaller devices.

It can also come as a pre-cabled solution and is ideally suited for handheld or body-worn applications when space is limited.

### SPACE SAVING

- Save up to 45% space
- Replace multiple connectors with only one
- Ultra compact interconnect solutions

### RELIABLE

- IP68 sealed mated and unmated
- 5,000 mating cycles
- Transfer data up to 10Gb/s

### LIGHTWEIGHT

- Reduce weight up to 75%
- Improve performance for handheld, body-worn or airborne applications
- Solve device miniaturization challenges

### PERSONALIZED

- Unique combination of power and signal
- Lower total cost of ownership
- Various locking systems, cabling & overmolding solutions and protective soft cap

FISCHER  
**MINIMAX™**  
SERIES





## HIGH DENSITY | SIGNAL & POWER | MINIATURIZATION

Perfectly suited for:

Limited space and lightweight applications | Combined needs of multiple signals and power | Instrumentation, testing equipment and military applications

## FISCHER **MINIMAX™** SERIES

Body style selection	J 4
Electrical & contact configurations	J 5
Mechanical coding	J 5
Technical dimensions	J 6
PCB hole layout	J 11
Part numbering	J 12
Accessories	J 13
Tooling	J 15
Technical information	J 16



## PLUGS

### CABLE MOUNTED



BODY STYLES	<b>MP11-L</b>	<b>MP11-S</b>	<b>MP11-Q</b>
Locking system	Push-pull	Screw-locking	Quick-release
Sealing	IP68	IP68	IP68
Design	Short/Overmolding	Short/Overmolding	Short/Overmolding

## RECEPTACLES

### CABLE MOUNTED



BODY STYLES	<b>MR50-L</b>	<b>MR50-S</b>	<b>MR50-Q</b>
Locking system	Push-pull	Screw-locking	Quick-release
Sealing	IP68	IP68	IP68
Design	Short/Overmolding	Short/Overmolding	Short/Overmolding

### PANEL REAR MOUNTED



BODY STYLES	<b>MR11-L</b>	<b>MR11-S</b>	<b>MR11-Q</b>
Locking system	Push-pull	Screw-locking	Quick-release
Sealing	IP68	IP68	IP68
Design	Front-projecting	Front-projecting	Front-projecting



Size	Pin layout	Number of contacts	Contact diameter [mm]	Wire size <sup>1)</sup>	PCB contacts	Current rating [A]	Rated voltage r.m.s [V]	Test voltage [kV] in mated position			
				Solder contacts	Pin diameter [mm]	IEC 60512-5-2-5b <sup>2)</sup>	IEC 60664-1 <sup>3)</sup>	IEC 60512-4-1 test 4a		DC	
								AC r.m.s.	DC	Contact to body	Contact to contact
06		2	0.5	maxø .70mm – AWG28 [7/36]	0.4	1.0	≤250	1.4	1.2	2.3	1.9
		2	1.3	maxø 1.33mm – AWG20 [26/34]	0.7	10					
		10	0.5	maxø .70mm – AWG28 [7/36]	0.4	1.0	≤250	0.9	0.9	1.5	1.2
		2	0.5	maxø .70mm – AWG24 [19/36]	0.4	5.0					
08		15	0.5	maxø .70mm – AWG28 [7/36]	0.4	1.0	≤250	0.9	0.9	1.5	1.2
		4	0.5	maxø .70mm – AWG24 [19/36]	0.4	5.0					
		13+2 <sup>4)</sup>	0.5	maxø .70mm – AWG28 [7/36]	0.4	1.0	≤250	0.9	0.9	1.5	1.2
		4	0.5	maxø .70mm – AWG24 [19/36]	0.4	5.0					
		20	0.5	maxø .43mm – AWG30 [7/38]	0.4	1.0	≤250	0.9	0.9	1.5	1.2
		4	0.5	maxø .70mm – AWG24 [19/36]	0.4	5.0					
		18+2 <sup>4)</sup>	0.5	maxø .43mm – AWG30 [7/38]	0.4	1.0	≤250	0.9	0.9	1.5	1.2
		4	0.5	maxø .70mm – AWG24 [19/36]	0.4	5.0					

<sup>1)</sup> Stranding values in brackets. Wire size information is based on Fischer Connectors standard cabling recommendation for configuration with 2 or 4 power contacts.

<sup>2)</sup> Recommended max. operating current per contact at 40°C temperature rise.

<sup>3)</sup> Recommended operating voltage at sea level. This rated voltage is a general purpose guideline where no other electrical safety standard applies. In case where other standards rule a specific use of the connector, then the application-specific safety criteria shall be considered first. This must be evaluated in the frame of equipment engineering.

<sup>4)</sup> Two advanced signal contacts for USB power are available for Solder (S) or PCB (P) receptacles.

RECEPTACLES	Size 06			
	Code 1	Code 2	Code 3	Code 4
	■	■	■	■

Size 08			
Code 1	Code 2	Code 3	Code 4
■	■	■	■

**Visual color coding**

Code 1, 3 have a beige contact block  
Code 2, 4 have a black contact block



**PLUGS**

**CABLE MOUNTED**

**MP11-L / PUSH-PULL**

BODY STYLE

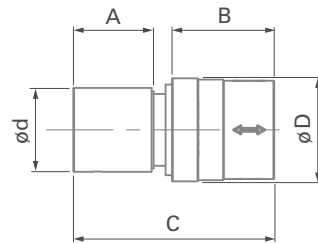

**MP11-Q / QUICK-RELEASE**

BODY STYLE

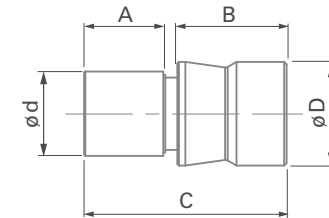

**MP11-S / SCREW-LOCKING**

BODY STYLE

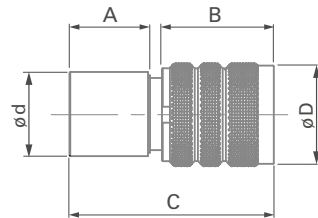

Size	Locking	ød	øD	A	B	C
06	Push-pull	Ø 8.5	Ø 9.9	10.1	12.8	~ 25.0
	Quick-release	Ø 8.5	Ø 9.9	10.1	13.6	~ 25.0
	Screw	Ø 8.5	Ø 9.9	10.1	14.0	~ 25.0
08	Push-pull	Ø 10.5	Ø 12.9	10.1	12.8	~ 25.0
	Quick-release	Ø 10.5	Ø 12.9	10.1	13.6	~ 25.0
	Screw	Ø 10.5	Ø 12.9	10.1	14.0	~ 25.0



**DIMENSIONS OF OVERMOLDING (AVAILABLE ON REQUEST)**

**CABLE MOUNTED**

**MP11-L/S/Q**

STRAIGHT OVERMOLDING

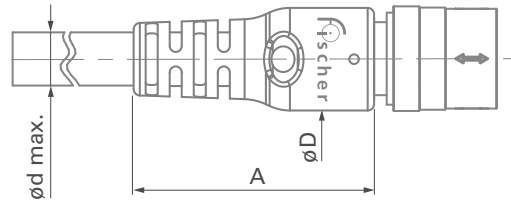

**MP11-L/S/Q**

RIGHT-ANGLE OVERMOLDING

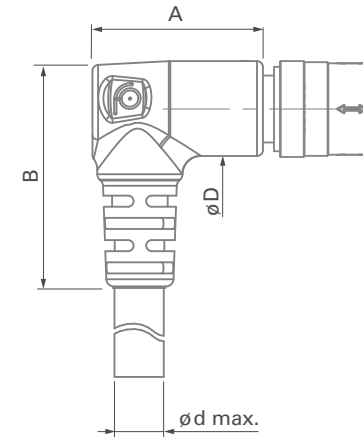

Size	Angle	$\varnothing d$	$\varnothing D$	A	B
06	Straight	$\varnothing 4.7$	$\varnothing 10.8$	30	-
	90°	$\varnothing 4.7$	$\varnothing 10.8$	23	30
08	Straight	$\varnothing 6.7$	$\varnothing 12.8$	30	-
	90°	$\varnothing 6.7$	$\varnothing 12.8$	23	30

All dimensions and images shown are in millimeters and are for reference only.





**RECEPTACLES**

**CABLE MOUNTED**

**MR50-L / PUSH-PULL**

BODY STYLE

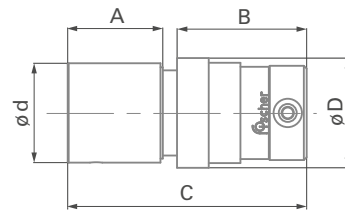

**MR50-Q / QUICK-RELEASE**

BODY STYLE

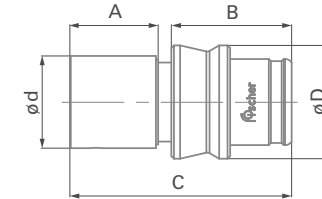

**MR50-S / SCREW-LOCKING**

BODY STYLE

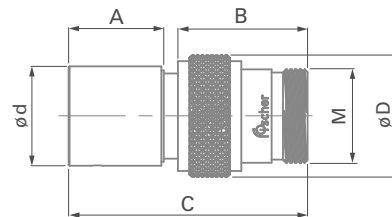

Size	Locking	ød	øD	A	B	C	M
06	Push-pull	Ø 8.5	Ø 9.9	10.1	13.7	~ 25.0	-
	Quick-release	Ø 8.5	Ø 9.9	10.1	13.7	~ 25.0	-
	Screw	Ø 8.5	Ø 9.9	10.1	13.7	~ 25.0	M8x2
08	Push-pull	Ø 10.5	Ø 11.6	10.1	13.7	~ 25.0	-
	Quick-release	Ø 10.5	Ø 12.9	10.1	13.7	~ 25.0	-
	Screw	Ø 10.5	Ø 12.9	10.1	13.7	~ 25.0	M10x2



## RECEPTACLES

### PANEL REAR MOUNTED

#### MR11-L / PUSH-PULL

BODY STYLE

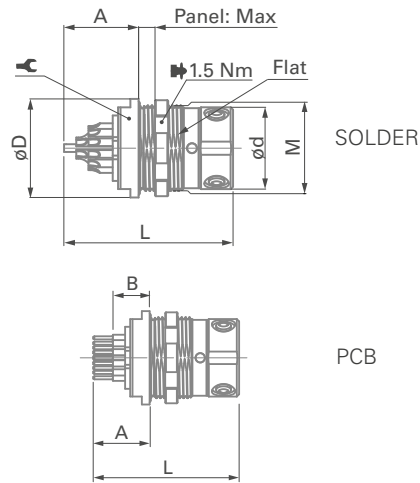

#### MR11-Q / QUICK-RELEASE

BODY STYLE

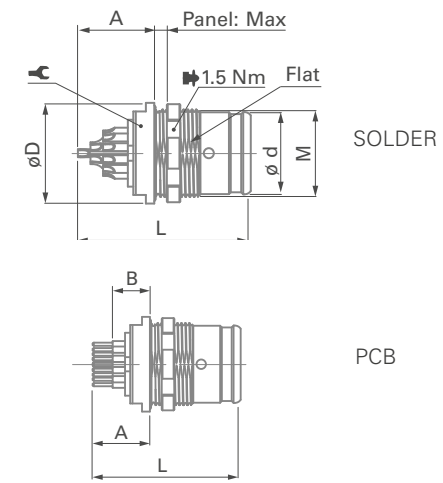

Size	Locking	Termination	ød	øD	A	B	L	Panel max.	M Panel thread	⌘
06	Push-pull	Solder	Ø 8.0	Ø 10.0	7.6	-	19.1	3.0	M8.5x0.35	8
		PCB	Ø 8.0	Ø 10.0	7.3	4.7	18.8	3.0	M8.5x0.35	8
	Quick-release	Solder	Ø 7.8	Ø 10.0	7.6	-	19.1	3.0	M8.5x0.35	8
		PCB	Ø 7.8	Ø 10.0	7.3	4.7	18.8	3.0	M8.5x0.35	8
08	Push-pull	Solder	Ø 10.0	Ø 12.0	9.1	-	20.6	3.0	M10.5x0.5	10
		PCB	Ø 10.0	Ø 12.0	7.3	4.7	18.8	3.0	M10.5x0.5	10
	Quick-release	Solder	Ø 9.8	Ø 12.0	9.1	-	20.6	3.0	M10.5x0.5	10
		PCB	Ø 9.8	Ø 12.0	7.3	4.7	18.8	3.0	M10.5x0.5	10

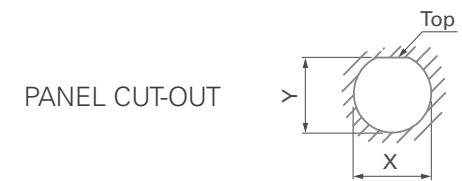

Size	X	Y
06	Ø 8.58 <sup>+0.1/0</sup>	8.25 <sup>+0.1/0</sup>
08	Ø 10.45 <sup>+0.1/0</sup>	10.2 <sup>+0.1/0</sup>

All dimensions and images shown are in millimeters and are for reference only.



## RECEPTACLES

### PANEL REAR MOUNTED

#### MR11-S / SCREW-LOCKING

##### BODY STYLE

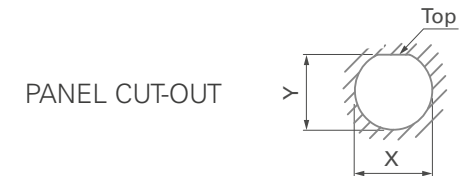
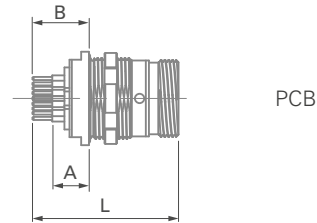
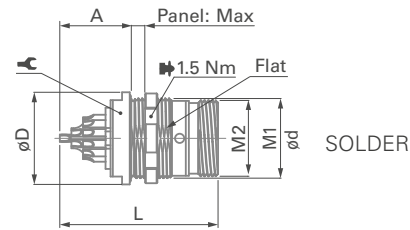

Size	Locking	Termination	ød	øD	A	B	L	Panel Max	M1 Panel thread	M2 Locking thread	↺
06	Screw	Solder	Ø 8.0	Ø 10.0	7.6	N/A	19.1	2.3	M8.5x0.35	M8x2	8
		PCB	Ø 8.0	Ø 10.0	7.3	4.7	18.8	2.3	M8.5x0.35	M8x2	8
08	Screw	Solder	Ø10.4	Ø 12.0	9.1		20.6	2.3	M10.5x0.5	M10x2	10
		PCB	Ø10.4	Ø 12.0	7.3	4.7	18.8	2.3	M10.5x0.5	M10x2	10

Size	X	Y
06	Ø 8.58+0.1/0	8.25+0.1/0
08	Ø 10.45+0.1/0	10.2+0.1/0



View from the back of the plug/front of receptacle

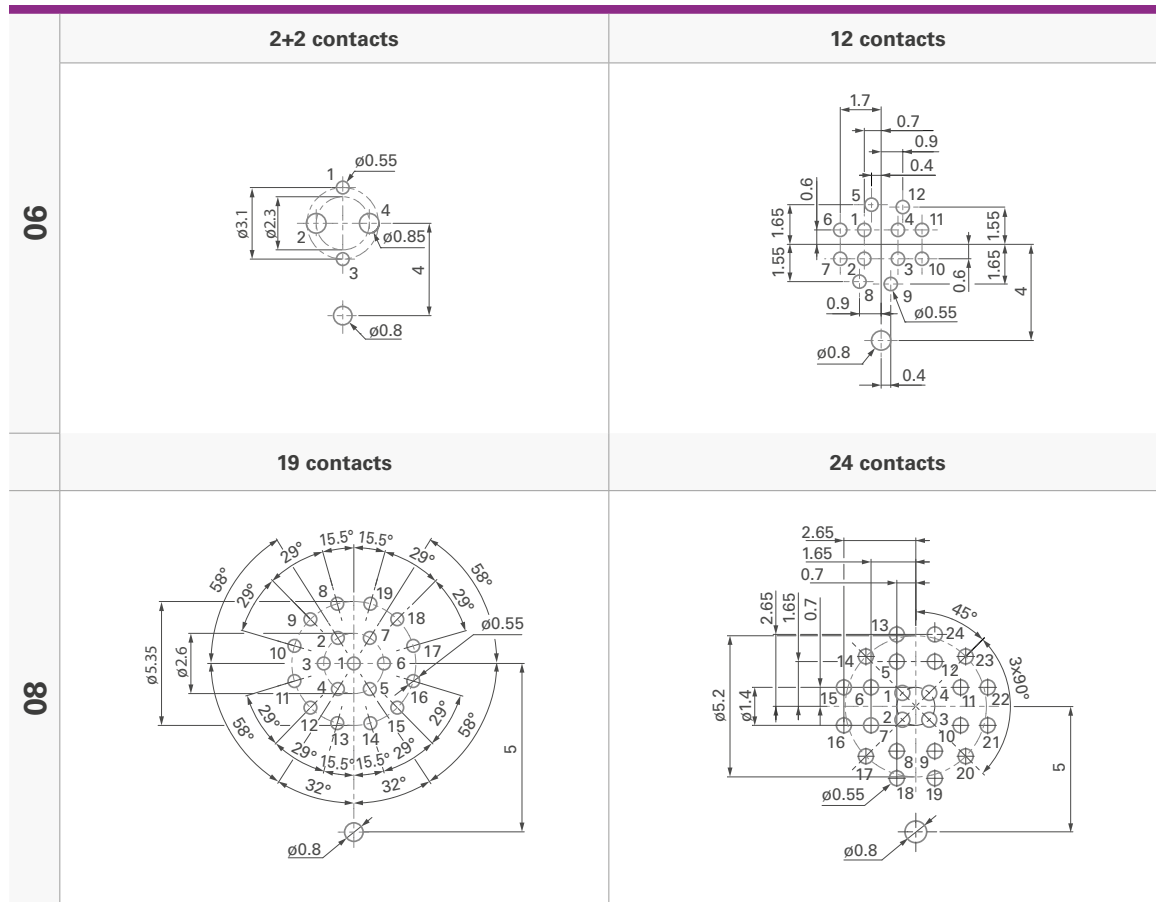

	2+2	12	19	24
<b>Power</b>	2 ; 4	5 ; 9	9; 12; 15; 18 <sup>1)</sup>	14; 17; 20; 23
<b>Ethernet</b>	-	1/6; 3/10; 7/8; 11/12 <sup>1)</sup>	8/19; 10/11; 13/14; 16/17 <sup>1)</sup>	15/16; 18/19; 21/22; 13/24 <sup>1)</sup>
<b>Advanced pin</b>	2 ; 4	-	13;19 <sup>2)</sup>	18;24 <sup>2)</sup>

<sup>1)</sup> Recommended

<sup>2)</sup> Optional on MR11

All dimensions and images shown are in millimeters and are for reference only.



Example:	Connector design				Contact block	Housing		Standard options			
	MP11	Z	L	08	0420	BK	1	Z	1	A	S
	MR11	W	S	08	2017	BK	2	E	1	A	P
	MR50	Z	Q	08	0019	BK	4	E	1	A	S

**Body style**

**MiniMax plug = MP**  
 ■ **MP11** = Cable mounted

**MiniMax receptacle = MR**  
 ■ **MR11** = Panel mounted  
 ■ **MR50** = Cable mounted

**Sealing level**

**MP11, MR50**  
 ■ **Z** = not applicable

**MR11**  
 ■ **W** = water sealing

**Locking system**

**MiniMax plug & receptacle**  
 ■ **L** = Push-pull locking  
 ■ **Q** = Quick-release  
 ■ **S** = Screw-locking

**Connector size**

■ **06** = Size 6  
 ■ **08** = Size 8

**Number of contacts**

■ **Digit 1** = Advanced contacts (if applicable)  
 ■ **Digit 2** = Power contacts (if physically larger compared to the other contacts)  
 ■ **Digit 3+4** = Remaining contacts

Available standard options:  
 0420  
 2418 (MR11)  
 0019  
 2017 (MR11, MP11)  
 0210  
 0202

**Contact termination**

**MP11, MR50**  
 ■ **S** = Solder contact

**MR11**  
 ■ **P** = PCB contact  
 ■ **S** = Solder contact

**Contact bloc**

■ **A** = Hermaphroditic (both MR and MP need to be "A")  
 ■ **F** = Female contacts (if MR = "F" than MP = "M")  
 ■ **M** = Male contacts (if MR = "M" than MP = "F")

**Insulating material**

■ **1** = PEEK

**O-ring material**

**MP11**  
 ■ **Z** = Not applicable

**MR11, MR50**  
 ■ **E** = EPDM

**Keying code**

■ **1** = Code 1 (insulator= Beige)  
 ■ **2** = Code 2 (insulator= Black)  
 ■ **3** = Code 3 (insulator= Beige)  
 ■ **4** = Code 4 (insulator= Black)

**Housing color**

■ **BK** = Black (standard)  
 ■ **AN** = Anthracite (on request)



## SOFT CAPS

### CABLE MOUNTED

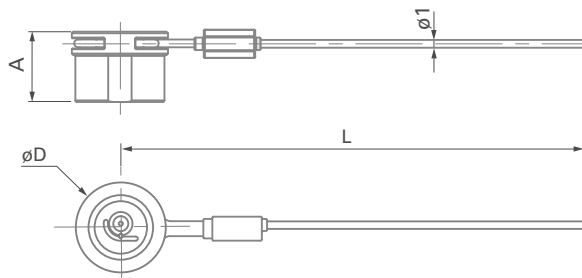
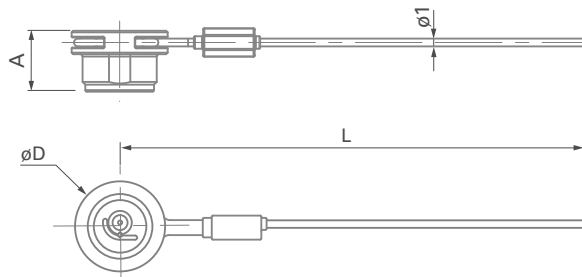

Size	Designation	Images	Push-pull	Quick-release	Screw-lock	A	øD	L	Part number
06	MP11 <sup>1)</sup>		•			9.6	10.0	200	MCP06C 1B2 A200 AA
				•	•	7.8	10.0	200	MCP06C 1B2 A200 BA
08	MP11 <sup>1)</sup>		•			9.6	12.3	200	MCP08C 1B2 A200 AA
				•	•	7.8	12.3	200	MCP08C 1B2 A200 BA

<sup>1)</sup> Crimp ferrule and heat shrink tube are included.

06	MR50 <sup>1)</sup>		•	•	•	9.0	10.0	200	MCR06C 1B2 A200 AA
08	MR50 <sup>1)</sup>		•	•	•	9.0	12.3	200	MCR08C 1B2 A200 AA

<sup>1)</sup> Crimp ferrule and heat shrink tube are included.

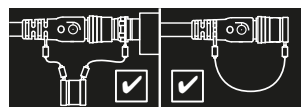

To avoid getting debris into the caps when the connectors are mated, please mate the caps together. Please make sure that the cap is in place when the plug or the receptacle is in unmated position.

All dimensions and images shown are in millimeters and are for reference only.



## SOFT CAPS

### PANEL MOUNTED

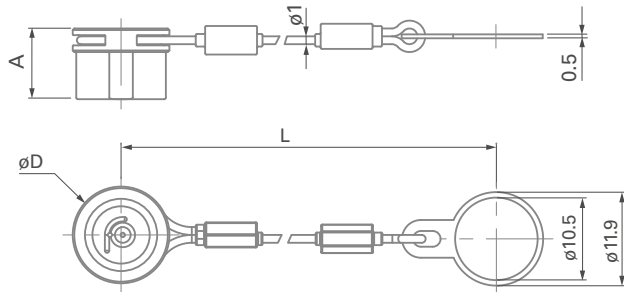

<b>06</b>	MR11 <sup>1)</sup>		•	•	•	9	10	95	MCR06P 1B2 A095 AA
<b>08</b>	MR11 <sup>1)</sup>		•	•	•	9.0	12.3	95	MCR08P 1B2 A095 AA

<sup>1)</sup>Crimp ferrule, heat shrink tube and mounting ring are included.

## BEND RELIEF

## HEAT SHRINKING TUBE

### CUTTING DIAMETERS

Size	Uncut	Level 1	Level 2	Part Number
<b>06</b>	ø2.9	ø3.9	ø5.7	MB06 A1BK

Size	Designation	Straight	Right-angle	Heat shrinking tube reference
<b>08</b>	MP11	•	-	Hellermann Tyton 152-41-G BK 24-6
		-	•	Hellermann Tyton 1152-4-G BK 24-6

### LEVEL

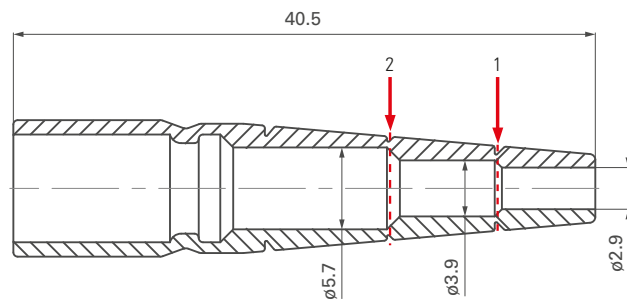



## SPANNER & NUT DRIVER

### DOUBLE-END OPEN SPANNER EXTRA THIN



Size	Part number	Opening across	Length	Fork thickness
06	TX00.008	8	96	2.3
08	TX00.010	10	104	2.5

Material – Chrome Alloy Steel, Chrome plated, Fork Angles – 15° and 75°.

### NUT DRIVER WITH T-HANDLE AND HEX DRIVE

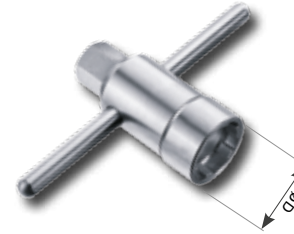

Part number	Thread size	Nut outer dia.	ø D	Hex drive
TX00.383	M8.5x0.35	10	14	7
TC00.007	M10.5 x 0.5	13	16	7

Material – Hardened Tool Steel, Nickel plated.

## CABLE ASSEMBLY TOOLING



Part number	Description
TX00.245	Standard «Daniels HX4» crimp tool used for manipulating the MiniMax MP11 size 08 dies. (TX00.379)



Part number	Description
TX00.379	Fischer Connectors specific cabling tool (dies) for inserting the contact block and fixing the back nut on MiniMax MP11 size 08. To be used with Daniels HX4 crimp tool (TX00.245)

For cabling tooling for MiniMax size 06, please contact your Fischer Connectors sales representative.

All dimensions and images shown are in millimeters and are for reference only.





## ENVIRONMENTAL & MECHANICAL DATA

Characteristic	Performance	Standard
<b>Sealing performance</b> mated and unmated	IP68; 2m submersion for 24 hours	IEC 60529
<b>Sealing performance Soft Cap</b>	IP67; 15cm submersion for 30 min	IEC 60529
<b>Operating temperature range</b> (with PUR cable)	-40°C to +85°C	IEC 60512-6-1 IEC 60068-2-14-Nb
<b>Corrosion resistance mated</b>	Salt mist 1,000 hours ; 5% salt solution, 35°C Plug and receptacle in mated position or with cap when unmated. Cosmetic changes may appear over time without impacting mechanical or electrical functions.	IEC 61300-2-1
<b>Endurance</b>	5,000 mating cycles Preserved mechanical and electrical functionality. Normal wear will appear.	IEC 60512-5-1 IEC 60512-5-2
<b>Vibration</b> (Screw-lock version only)	10 to 2000 Hz, 1.5 mm or 15g, 12 sweep cycles per axis, 20 minutes per 10-2000-10 Hz sweep cycle, no discontinuity >1µs	MIL-STD-202 G Method 204D Condition B
<b>Unlocking Force</b> (Quick-release version only)	Size 06 = Typical 25N±40% Size 08 = Typical 50N±40%	
<b>Shock</b>	300 g	MIL-STD-202 G Method 213

## ELECTRICAL DATA

Characteristic	Performance	Standard
<b>Contact resistance</b>	5 mΩ (typical value)	IEC 60512-2-1-2a; IEC 60512-2-2-2b
<b>Shell resistance <sup>1)</sup></b>	<50 mΩ (Cabled)	IEC 60512-2-6-2f
<b>Insulation resistance</b>	>10 <sup>10</sup> Ω	IEC 60512-3-1-3a
<b>Shielding effectiveness</b>	360° shielded	-

<sup>1)</sup> Measured for a mated pair of panel receptacle and cable plug between the grounding pin and the cable shielding.



## MATERIAL & SURFACE TREATMENTS

Metal Parts	Material		Finish	
	Designation ISO	Standard	Designation	Standard
Housing, Nut	Brass CuZn39Pb3	CW614N UNS C 38500	Chrome over Nickel	SAE-AMS2460
Back nut (MP11, MR50)	Brass CuZn39Pb3	CW614N UNS C 38500	Nickel	SAE-AMS-QQ-N-290B SAE-AMS2404G
Ground contact	Brass CuZn39Pb3	CW614N UNS C 38500	Nickel	SAE-AMS-QQ-N-290B SAE-AMS2404G
Push-pull locking spring Quick-release locking spring	Stainless steel	X10CrNi18-8 (1.4310)	-	-
Contacts	- Male, Ground Pin	Brass CuZn39Pb3	1µm Gold over Nickel	MIL-DTL-45204D Type I; ASTM B488 MIL-DTL-45204D Type I; ASTM B488
	- Female	Bronze CuSn4Zn4Pb4		
Ball-locking	Ceramic Si3N4	-	-	-

Insulator and sealing		International symbol	Flammability
Insulators		PEEK <sup>1)</sup>	UL 94 V-0
O-rings	- General	FPM (Viton®)	UL 94 V-0
	- Interface	EPDM	-
Sealant materials	- Cable connectors	Bi-component epoxy	-
	- Panel receptacles	Silicone	-
Overmolding material	- Cable connectors	TPU	UL 94 V-0
Cap	- Cable connectors	TPV (Santoprene)	UL 94 HB
	- Panel receptacles		





<sup>1)</sup> Or any material in the PAEK family that provides equal or better overall performances.

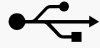

## DATA TRANSMISSION

---

The data transmission performance of the Fischer MiniMax™ Series has been tested for most popular protocols that are used in a variety of applications today.

Protocol	Number of contacts required	MINIMAX
USB 2.0 	4	yes
USB 3.0 <b>SS</b> 	9	application dependent
Ethernet Cat 5e (1Gb/s) 	8	yes
Ethernet Cat 6a (10Gb/s) 	8	yes
<b>HDMI</b>	19	yes

It is important to note that the connector is only a small part of the equation when talking about data transmission performances.

The cable quality, the cabling process and the cable length are other, more critical factors that will directly influence the performances of the cable assembly.